

# **THE INSTITUTIONALIZATION OF POLITICAL PARTIES, RESILIENCE, AND STRATEGIC CAMPAIGNS**

**Dr. Ir. Hasto Kristiyanto, M.M.**

**CALD Conference**  
Manilla, March 27, 2026

# The Triangle of Authoritarian Populism Leadership\*

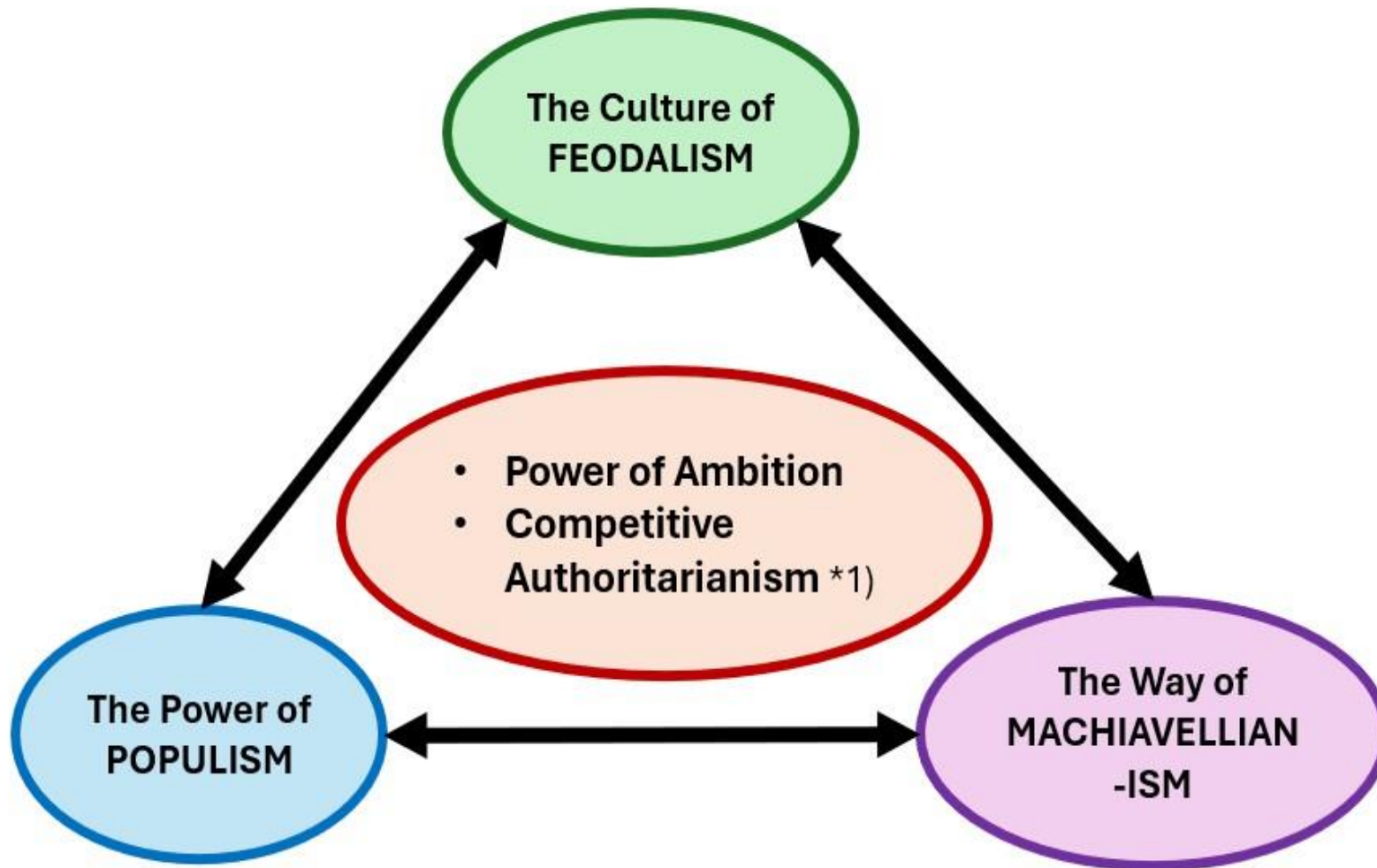

\*Riset Program Doktor SKSG Universitas Indonesia: “Kepemimpinan Strategis Politik, Ideologi, dan Pelembagaan serta Relevansinya Terhadap Ketahanan Partai” (Kristiyanto, 2024).

\*1) *Competitive Authoritarianism: Hybrid Regimes after the Cold War* (Levitsky & Lucan, 2009).

# ABUSE OF POWER CARRIED OUT BY PRESIDENT JOKO WIDODO



Ammunition:  
State Budget (APBN -  
Ministry of Finance)



- Automatic budget adjustment for the 2024 fiscal year
- Social assistance allocation of Rp 490 trillion



# Party Resilience Model

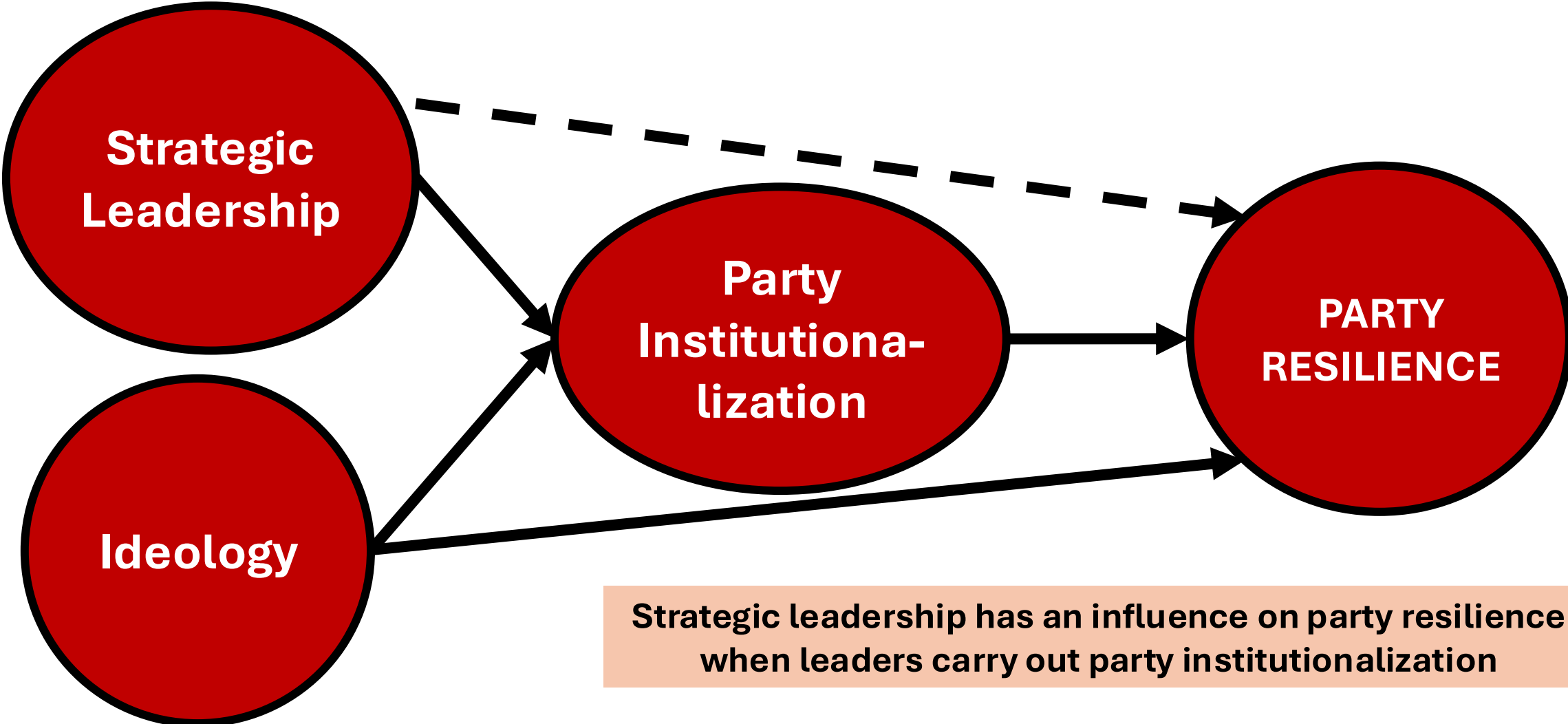

Strategic leadership has an influence on party resilience when leaders carry out party institutionalization

# THE INFLUENCE MODEL OF KSP, IDEO, AND PLMB ON PARTY RESILIENCE

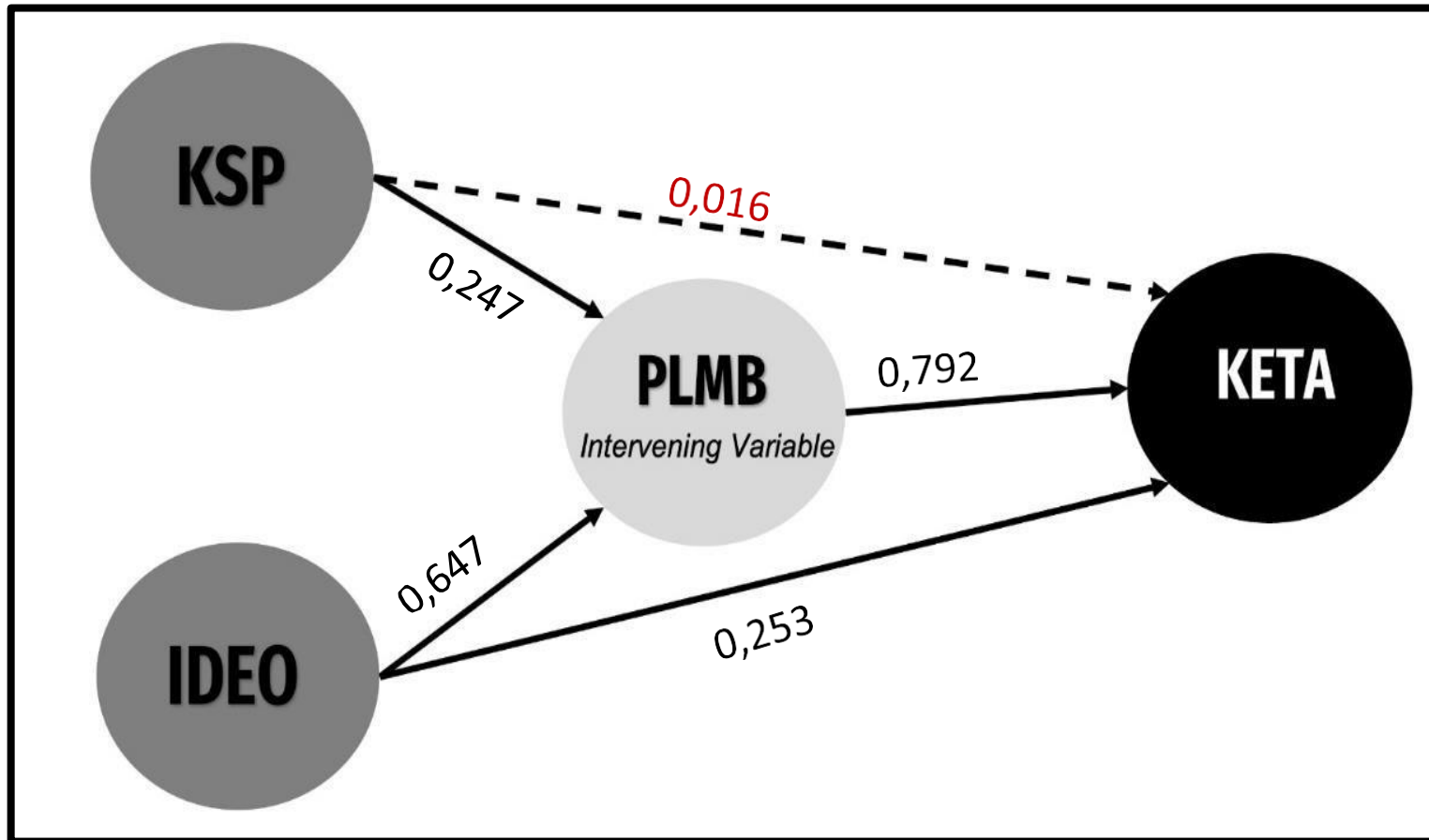

**KSP:** Strategic Leadership

**IDEO:** Ideology

**PLMB:** Party

Instituzionalitasion

**KETA:** Party Resilience

**Strategic Leadership** has an **influence** on the **party's resilience** if the leader **institutionalizes** the party

Direct and Indirect Influence Model on KSP,  
IDEO, PLMB, and KETA Variables

Source : Results of Researcher Analysis (2024)

# CONSTRUCT AN INSTITUTIONALIZED MEASUREMENT MODEL (PLMB)

Variable	Dimension	Indikator	Symbol	LF	
Party Institutionalization (PLMB)	System (SISTEM)	1. Regulation	SISTEM1	0,859	
		2. Rutinity	SISTEM2	0,875	
		3. Representation	SISTEM3	0,821	
			SISTEM4	0,850	
	Reification (REIF)	1. The Existence of Parties in the Eyes of the People		REIF1	0,787
				REIF2	0,781
				REIF3	0,818
	Decision Autonomy (OTO)	1. Freedom of Decision-Making	OTO1	0,847	
		2. Decision Making Strategy		OTO2	0,851
				OTO3	0,881
	Value (Nilai)	1. Internalization of Institutional Values		Nilai1	0,862
			Nilai2	0,833	
			Nilai3	0,853	
Party Functions (FP)	1. Political recruitment	FP1	0,829		
	2. Political education	FP2	0,856		
	3. Leadership regeneration	FP3	0,862		
	4. Representasi	FP4	0,884		
	5. Agregasi kepentingan	FP5	0,917		
	6. Political socialization	FP6	0,871		
	7. Political participation	FP7	0,874		
	8. Conflict organizer	FP8	0,871		
	9. Political communication	FP9	0,875		
		FP10	0,870		
	10. International relations	FP11	0,848		

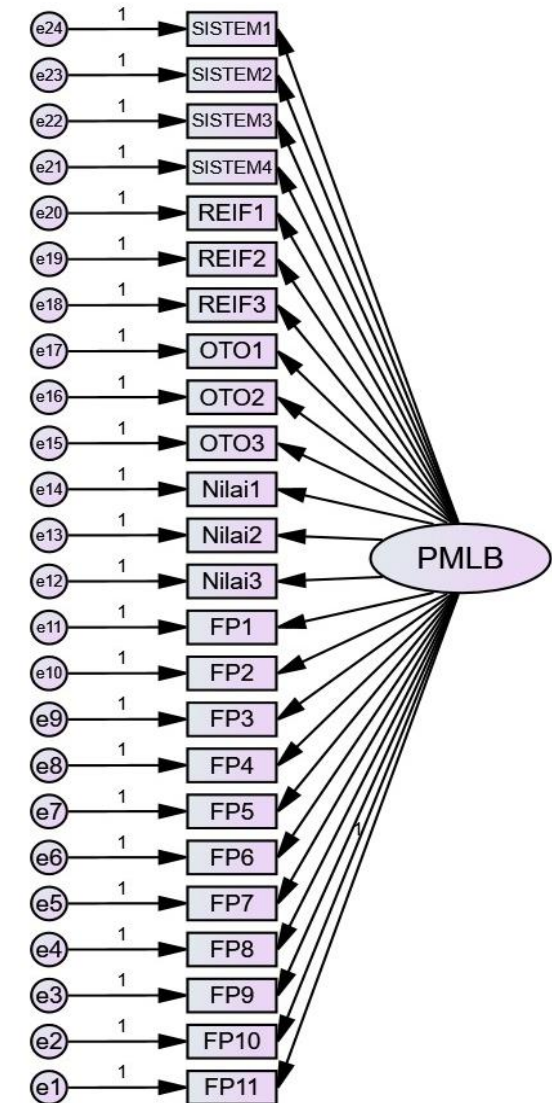

The highest loading factor value is the Party Function dimension (0.869) with indicators namely Aggregation of Interests and Representation

**PLMB Loading Factor Value Table**

Source: Processed by Researcher (2024)

**PLMB Measurement Model Chart**

Source : Results of Researcher Analysis (2024)

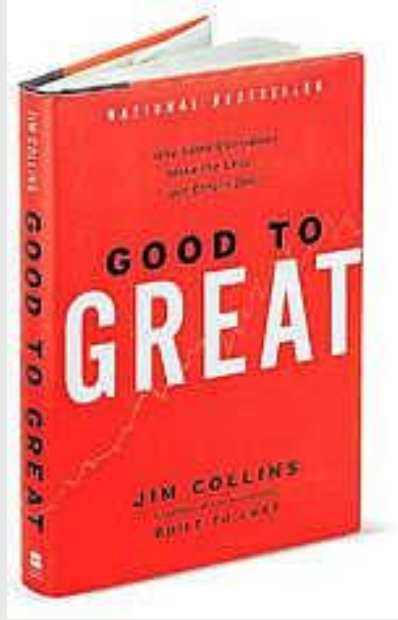
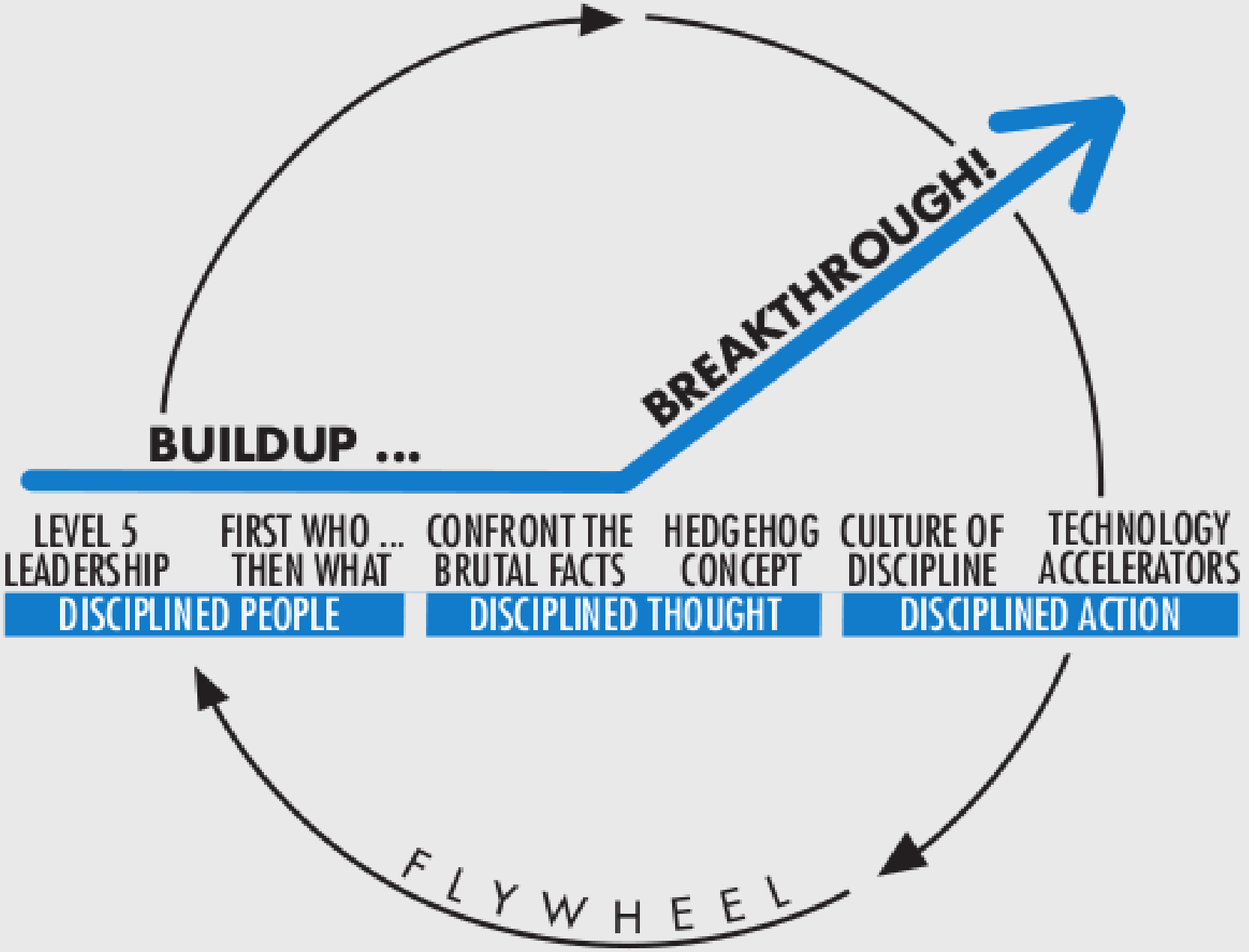

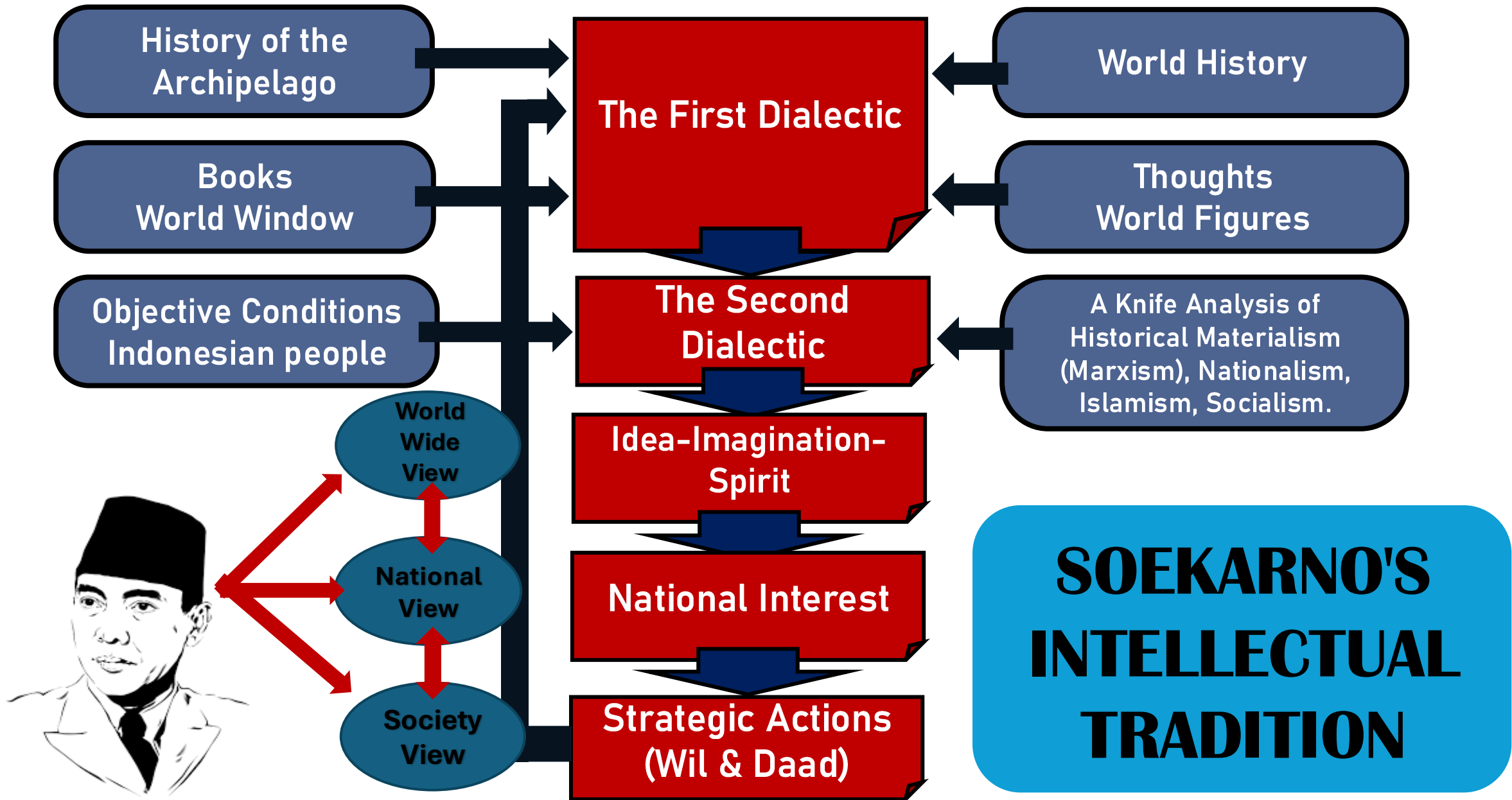

# Soekarno's Geopolitical Cycle

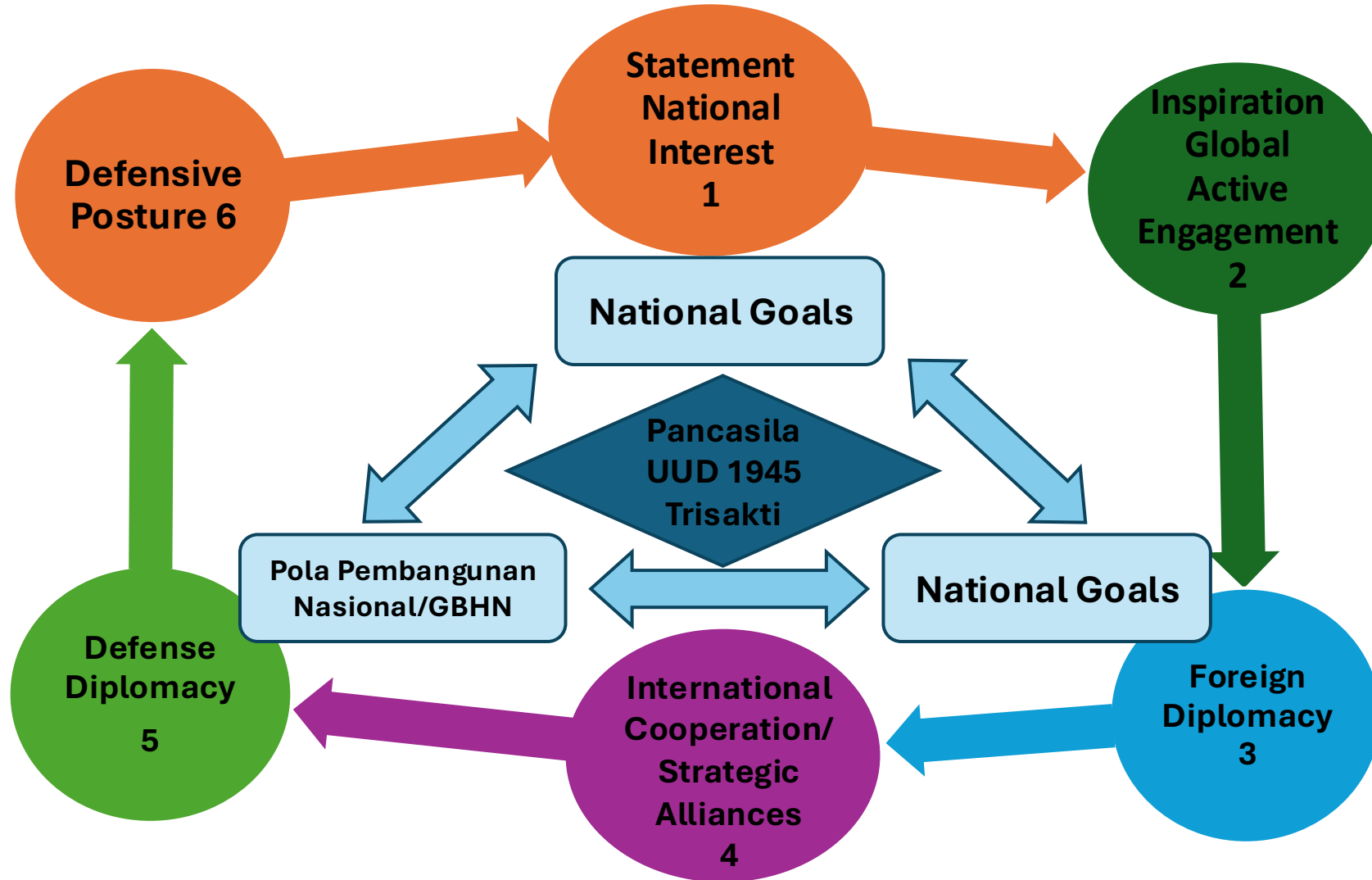



## Regional Head Candidate Assessment Report

Test Number : 001/P3/DKI-6/050516  
Name : XYZ  
Departments : \_\_\_\_\_  
Work Areas : \_\_\_\_\_

Date : \_\_\_\_\_  
Education : \_\_\_\_\_  
Gender : Laki-Laki  
Age :      Tahun

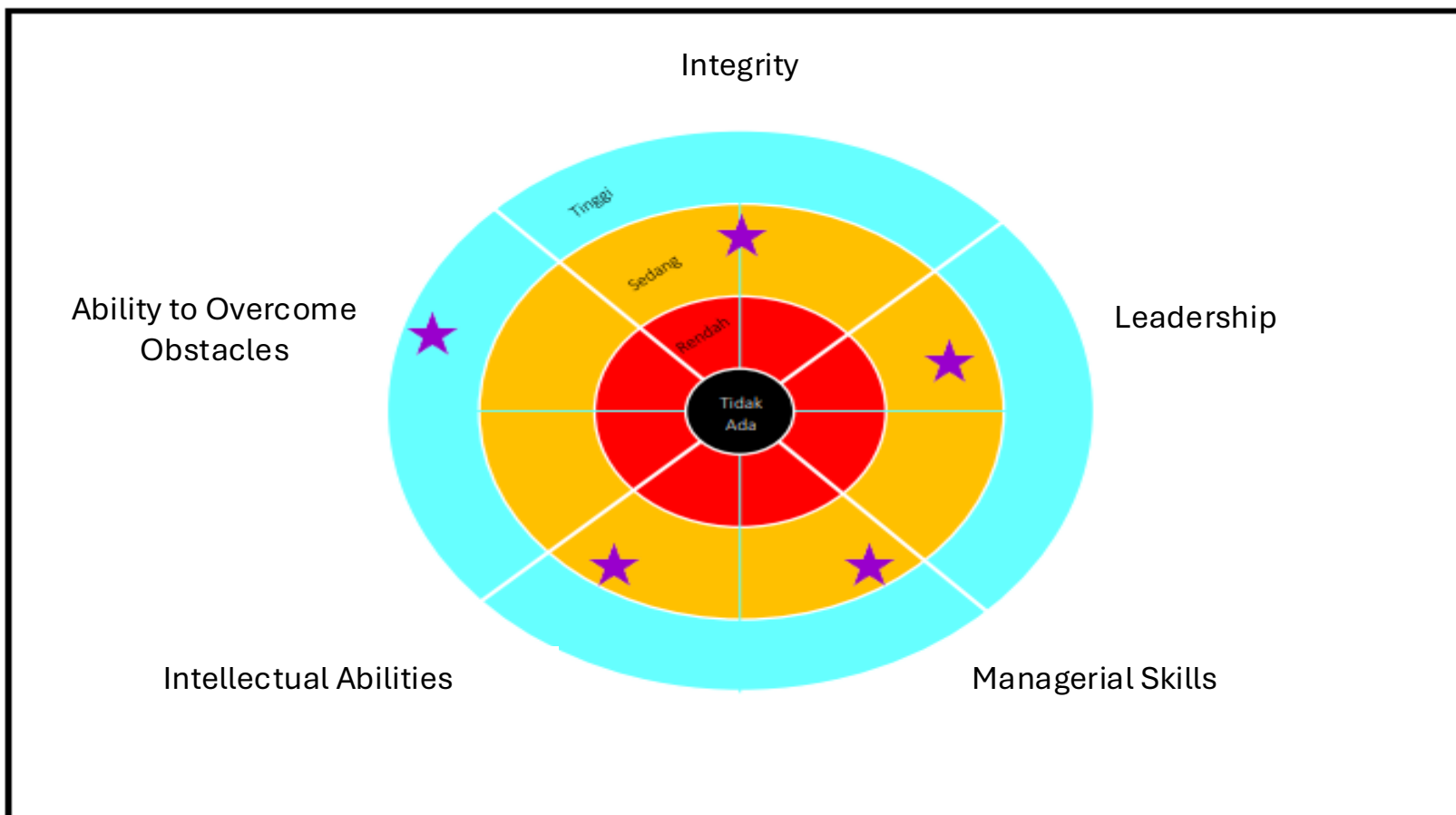

# Megawati Seven Principles (MSP)

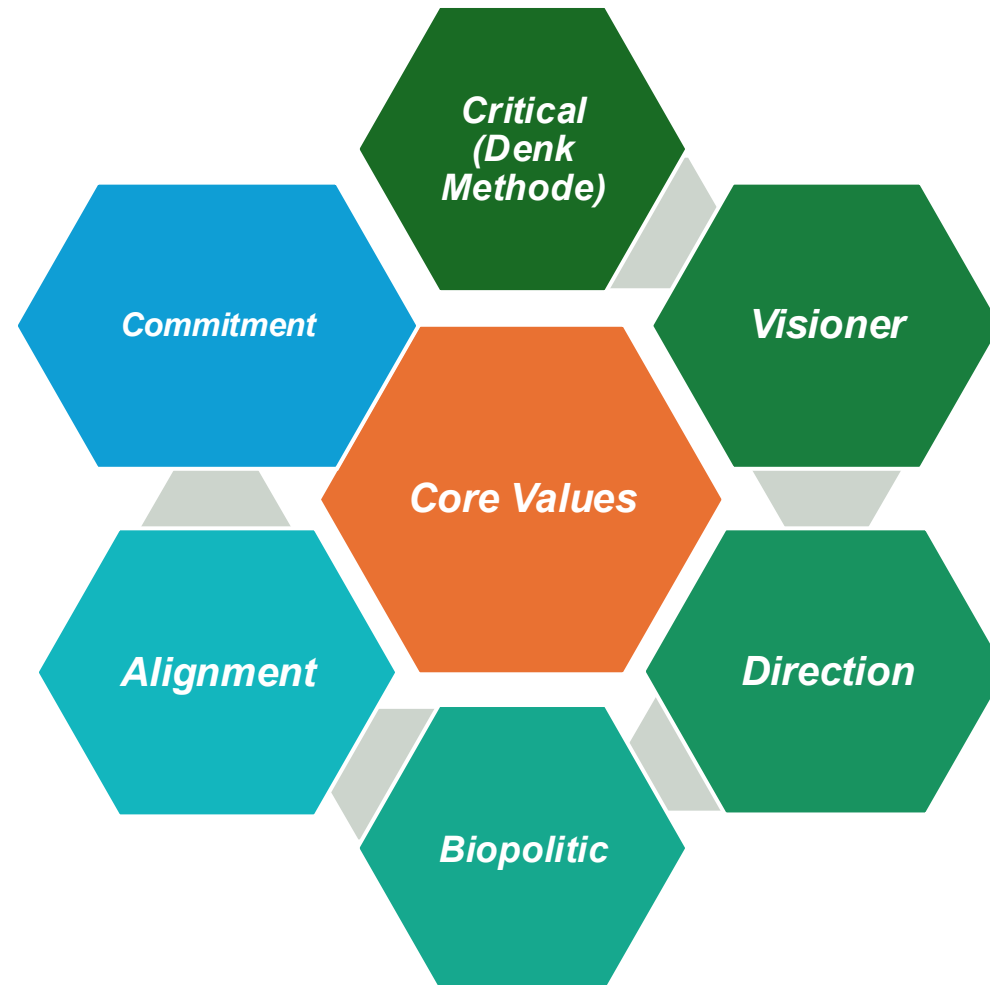

**Megawati's Seven Principles of Political Strategic Leadership as a Synthesis of Megawati Soekarnoputri's Political Strategic Leadership Theory**

*Source: Constructed by Researcher (2023)*



**FOR FIGHTING NATION,  
THE JOURNEY NEVER ENDS.**

# EIGHT PARTY CHALLENGES -1

## **1. Global Geopolitical Challenges**

The impact of global geopolitical rivalries affecting national stability and the direction of state policies.

Global pressure on national political and economic sovereignty.

## **2. Ecological and Environmental Crisis**

Global warming, deforestation, illegal logging, and development policies that neglect sustainability.

Threats to the future of the people and the homeland.

## **3. Internal Party Factionalization**

The potential for conflict arising from individual or group interests acting in the name of the Party.

The risk of 'two-faced politics' and weakening organizational cohesion.

## **4. External Interference and Interests**

Intervention by political power, economic forces, and oligarchic interests attempting to influence the Party's direction and sovereignty.

The threat of divide et impera against Party unity.



# EIGHT PARTY CHALLENGES -2

## **5. National Economic Issues**

Fiscal constraints, large debt burdens, unemployment, poverty, and economic inequality.

Pressure on the state's commitment to support the common people (*wong cilik*).

## **6. Unjust Legal System**

Selective law enforcement that strays from the public's sense of justice. Declining public trust in state institutions.

## **7. Social and Leadership Crisis**

Increasing social dissatisfaction due to inequality and abuse of power. The decline of ethics, morality, and exemplary conduct in public life.

## **8. Political Industrial Complex**

State governance influenced by business-political interests. Democracy risks becoming merely procedural and losing its people-centered spirit



# PDI Perjuangan's Responses and Strategies (Resilience) – 1

## **1. Strengthening Ideology as the Main Framework**

Positioning the principles of Pancasila (June 1, 1945) and the teachings of Bung Karno as the foundation of values, policy direction, and the goals of the struggle.

Ideology serves as the primary unifying force that prevents factionalization and internal conflict.

## **2. Strategic and Guided Leadership**

Consistently implementing the directions and instructions of the Chairperson, Mrs. Megawati Soekarnoputri.

Maintaining the Party character as a “Democratic Party” that is guided, disciplined, and authoritative.

## **3. Party Institutionalization and Consolidation**

Post-6th Congress consolidation as a momentum to strengthen: IDEOLOGY, ORGANIZATION, CADRES, & PARTY RESOURCES

Positioning the 1st National Working Meeting (Rakernas I) as a strategic forum to strengthen party resilience

## **4. Maintaining Cadre Solidarity and Loyalty**

Prioritizing loyalty, dedication, and organizational discipline.

Rejecting “two-faced politics” and opportunistic behavior.

Managing internal dynamics through deliberation, merit system, and prioritizing the interests of the Party



# PDI Perjuangan's Responses and Strategies (Resilience) – 2

## **5. Building People-Based Party Sovereignty**

Engaging directly with the grassroots, strengthening the base, and expanding support.

Practicing people-centered politics, humanitarian politics, and siding with the common people (*wong cilik*).

Reviving Bung Karno's teaching: unity with the people as the main weapon.

## **6. Fighting Spirit and Revolutionary Patience**

Avoiding complacency despite having political strength.

Maintaining a fighting spirit, firmness of stance, and revolutionary patience in facing pressure.

## **7. Politics of Ethics, Morality, and Exemplary Conduct**

Upholding values such as *Tat Twam Asi*, *Satyam Eva Jayate*, and humanitarian politics.

Responding to the crisis of leadership by practicing ethical and moral politics.

## **8. Caring for the Homeland as Part of the Struggle**

Making ecological movements (tree planting, environmental protection) an expression of ideological politics.

Linking the party's struggle with environmental sustainability and the future of the nation.



# **CORE OF PDI PERJUANGAN'S RESILIENCE:**

**PDI Perjuangan's resilience is built upon:**

- **A strong ideology**
- **Strategic leadership**
- **Robust party institutionalization**
- **Organic closeness with the people**
- **An enduring and unextinguished fighting spirit**



**WITH THIS FOUNDATION, PDI PERJUANGAN IS ABLE TO FACE THE STORMS OF CONTEMPORARY CHALLENGES, REMAIN SOLID, AND CONTINUE TO MOVE FORWARD FOR A GREATER INDONESIA**

<b>BACKGROUND</b>	<b>SOEKARNO</b>	<b>MEGAWATI SOEKARNOPUTRI</b>
<b>EMERGENCE</b>	<ol style="list-style-type: none"> <li>1. A dark era caused by colonialism and imperialism; the rising tide of humanitarian revolution; the collapse of European feudalism; the awakening of Asian and African nations.</li> <li>2. Responding to the longing for a just ruler (<i>Ratu Adil</i>).</li> </ol>	<p>Physical revolution; a living witness to the consolidation of the state; the era of independence of Asian and African nations; the emergence of socialist states and the atomic revolution; recolonialism in Indonesia</p>
<b>CONSOLIDATION OF THOUGHT</b>	<ol style="list-style-type: none"> <li>1. Bung Karno's intellectual tradition was built from the dialectic between Nationalism, Islamism, and Marxism.</li> <li>2. A dialectic between world history and the nation's civilization.</li> <li>3. Responding to the mandate of the people's suffering.</li> </ol>	<ol style="list-style-type: none"> <li>1. Grounding Bung Karno's ideas through critical, dialectical, and contemplative thinking methods.</li> <li>2. Addressing the issues of the people, the nation, and the world through Soekarno's thought.</li> <li>3. Synthesizing and contemplating Soekarno's ideas in relation to the universe</li> </ol>
<b>MOVEMENT METHODS</b>	<p>Non-cooperation by prioritizing agitation and propaganda through PNI as the main instrument of struggle</p>	<p>Loyalty to convictions, institutionalizing the party, and strengthening grassroots foundations by utilizing the power of ethics, morality, and exemplary conduct, as well as legal avenues through PDI and PDI Perjuangan</p>

<b>LATAR BELAKANG</b>	<b>BUNG KARNO</b>	<b>MEGAWATI SOEKARNOPUTRI</b>
<b>PARTY CONSOLIDATION</b>	<ol style="list-style-type: none"> <li>1. The party is led by ideas, concepts, thought, imagination, and a vision for the future as embodied in Pancasila of June 1, 1945.</li> <li>2. Political education and cadre formation serve as the main backbone of party development: every Wednesday is designated as a day for political courses. Building the people's consciousness and critical thinking.</li> <li>3. PNI functions as a tool of agitation and propaganda against colonialism, while also fostering the mentality of a fighting nation.</li> </ol>	<ol style="list-style-type: none"> <li>1. Engaging in politics to carry out Soekarno's teachings and to correct history as a result of de-Soekarnoization.</li> <li>2. Reviving grassroots strength through a 'silent revolution' across the entire archipelago.</li> <li>3. Consolidating all Nationalist-Soekarnoist forces within PDI and PDI Perjuangan.</li> <li>4. PDI Perjuangan as an instrument for organizing the people to realize the ideals of a Greater Indonesia.</li> <li>5. Institutionalizing the party (leadership, ideology, fighting spirit, and party resilience).</li> </ol>
<b>POLITICAL CADRE TRAINING</b>	<ol style="list-style-type: none"> <li>1. In and out of prison; exiled and attempts made to break his spirit.</li> <li>2. Defamed as a collaborator with Japan.</li> <li>3. Repeated threats and attempts on his life</li> </ol>	<ol style="list-style-type: none"> <li>1. Leadership cadre formation directly guided by Soekarno.</li> <li>2. Slander and divide et impera within the party and Bung Karno's family.</li> <li>3. Investigations by the police, the prosecutor's office, and intelligence surveillance on charges of subversion.</li> <li>4. Internal and external betrayal.</li> </ol>

# INTERNAL CHALLENGE: UNIFYING THE VISION OF STRUGGLE

